



- Cylinder
- Calculation
- SI
- SI A.
- SIB
- SQ
- DNT
- SC / SU
- SCT
- SC A.
- SL
- DN
- DSN
- DN/DSN A.
- MA
- MAC
- MA/MAC A.
- MAL
- MALC
- MAL/MAC A.
- SDA
- CQ2
- TCQ2
- ADN
- TADN
- PPRM
- MHL2
- Pneumatic Fingers
- MXH/MXQ
- CJP
- CJ2**
- CDU
- TN
- CXS
- MGP
- MSQ

Ordering Code

C D J2	B	F	6 x 15	R	MT
Magnet	Installation Type	Foot	Bore	Stroke	Position of port on end cover without rod
Blank: Without magnet D: With magnet	B: Bacis type D: Double earing (except Ø6)	F: Flange type L: Foot type	6 10 16	Blank: Radial (except Ø6) R: Axial Only double bearing type has radial	Blank: Without sensor * Please refer to Stroke/Sensor Switch Model chart to choose sensor model. * No such item when magnet is not applied. * Standard wire length is 1 meter, please specify for other length

Stroke/Sensor Switch Model

* To choose proper sensor switch, please refer to stroke/ sensor switch chart.
Lead wire length code: Blank - 0.5 m, L - 3 m. Example: C73, C73L.
No additional accessory is required for sliding type of sensor switch installation.

Bore (mm)	Standard Stroke	Sensor Switch Code		Channel installation type Sensor switch Not Suitable
		Tie-up Type Sensor Switch	Sensor Switch Code (Direct installation)	
6	15, 30, 45, 60	D-C73L D-H7A1L D-C76L DH7BL D-C80L	BJ2-006	D-A72L D-A73L D-A76L D-A80L D-F79L D-J79L
10	15, 30, 45, 60, 75, 100, 125, 150		BJ2-010	
16	15, 30, 45, 60, 75, 100, 125, 150, 175, 200		BJ2-016	

Specification

Bore (mm)	6	10	16
Operation Fluid	Air		
Operation	Double Acting		
Min. Operation Pressure	1.05 MPa		
Max. Operation Pressure	0.7 MPa		
Ambient and fluid temp	5 ~ 60 °C		
Cushion	Rubber Gasket Cushion / Air Cushion		
Rod Operation Speed	50 ~ 750 mm/s		
Tolerance Stroke	+1.0 mm 0 mm		
Lubricant	Non-lub		
Port Size	M5 x 0.8		

CJ2 Series (Ø6 ~ Ø16)

Stainless Steel Mini Cylinder Double Acting



Overall Dimension

CJ2B Double Acting

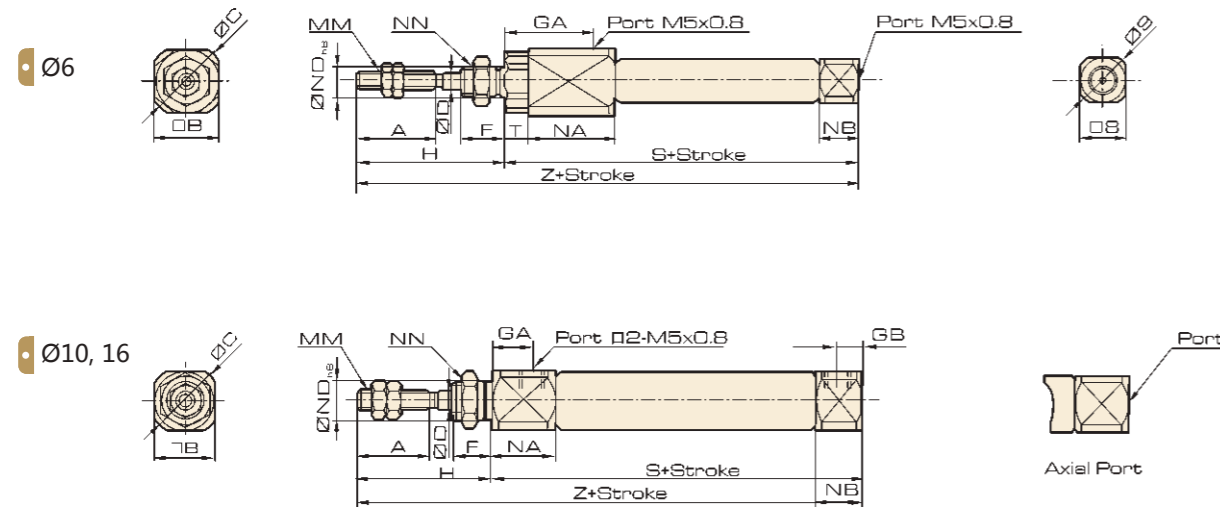

Dimension

Bore (mm)	A	B	C	D	F	GA	GB	H	MM	NA	NB	ND h8	NN	S	T	Z
6	15	12	14	3	8	14.5	-	28	M3x0.5	16	7	6	M6x1.0	49	3	77
10	15	12	14	4	8	8	5	28	M4x0.7	12.5	9.5	8	M8x1.0	46	-	74
16	15	18	20	5	8	8	5	28	M5x0.8	12.5	9.5	10	M10x1.0	47	-	75

Foot/ Flange

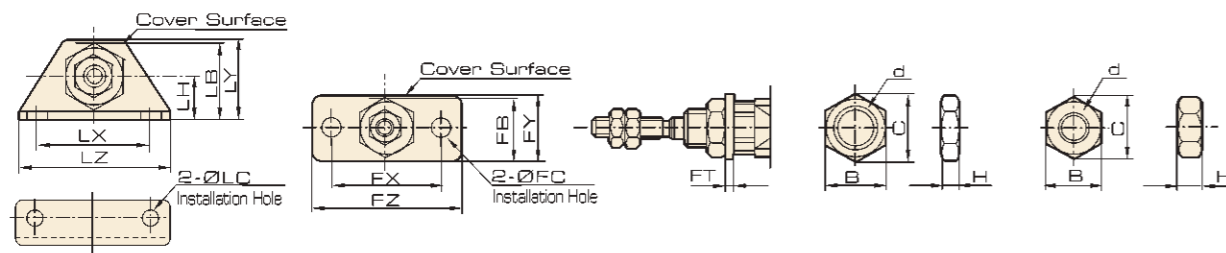

Dimension

Bore (mm)	Foot Seat						Flange						Installation Nut				Rod end Nut							
	Parts No.	LB	ΦLC	LH	LX	LY	LZ	Parts No.	FB	ΦFC	FX	FY	FZ	FT	Parts No.	B	C	d	H	Parts No.	B	C	d	H
6	CJ-L006B	13	4.5	9	24	16.5	32	CJ-F006B	11	4.5	24	14	32	1.6	SNJ-006B	8	9.2	M6x1	4	NTJ006A	5.5	6.4	M3x0.5	2.4
10	CJ-L010B	15	4.5	9	24	16.5	32	CJ-F010B	13	4.5	24	14	32	1.6	SNJ-010B	11	12.7	M8x1	4	NTJ010A	7	8.1	M4x0.7	3.2
16	CJ-L016B	23	5.5	14	33	25	42	CJ-F016B	19	5.5	33	20	42	2.3	SNJ-016B	14	16.2	M10x1	4	NTJ015A	8	9.2	M5x0.8	4

CJ2 Series (Ø6 ~ Ø16)

Stainless Steel Mini Cylinder Double Acting

ISO9001:2015 CE

Overall Dimension

CJ2D Double Earring Type

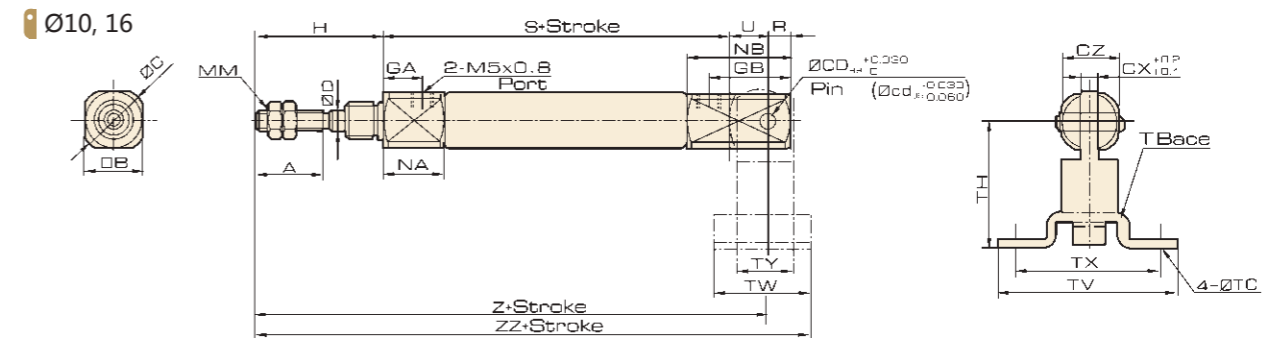

Bore (mm)	A	B	C	CD(cd)	CX	CZ	D	GA	GB	H	MM	NA	NB	R	S	U	Z	ZZ
10	15	12	14	3.3	3.2	12	4	8	18	28	M4x0.7	12.5	22.5	5	46	8	82	93
16	15	18	20	5	6.5	18	5	8	23	28	M5x0.8	12.5	27.5	8	47	10	85	99

T Base

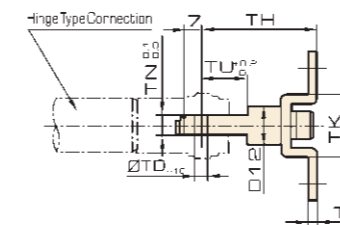

Hinge with Pin

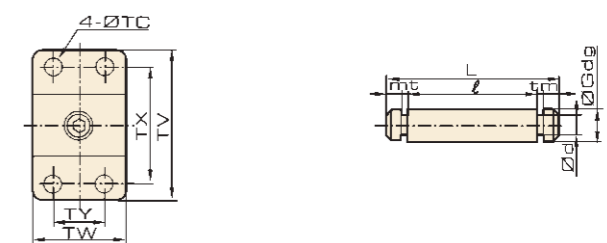

Bore (mm)	Part Code	T Type piston rod clevis										Pin for piston rod clevis							
		TC	TD ^{H10}	TH	TK	TN	TT	TU	TV	TW	TX	TY	Part Code	Dd9	Φd	L	e	m	t
10	CJ-T010B	4.5	3.3 ^{+0.048}	29	18	3.1	2	9	40	22	32	12	CD-J010	3.3 ^{-0.03}	3	15.2	12.2	1.2	0.3
16	CJ-T016B	5.5	5 ^{+0.048}	35	20	6.4	2.3	14	48	28	38	16	CD-Z015	5 ^{-0.03}	4.8	22.7	18.3	1.5	0.7

I Type Piston rod clevis

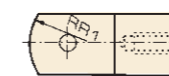

Y Type Piston rod clevis

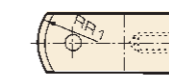

Pin for piston rod clevis

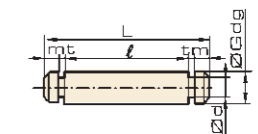

Bore (mm)	Part Code	I Type piston rod clevis						Y Type piston rod clevis						Pin for piston rod clevis									
		A1	ND ^{H10}	L1	MM	U1	NX	R1	Part Code	A1	ND ^{H10}	L1	MM	U1	NX	R1	Part Code	ΦDdg	L	d	e	m	t
10	I-J010B	8	3.3 ^{+0.048}	21	M4x0.7	9	3.1	8	Y-J010B	8	3.3 ^{+0.048}	21	M4x0.7	10	3.2	8	IY-J010	3.3 ^{-0.03}	16.2	3	12.2	1.7	0.3
16	I-J016B	8	5 ^{+0.048}	25	M5x0.8	14	6.4	12	Y-J016B	11	5 ^{+0.048}	21	M5x0.8	10	6.5	12	IY-J015	5 ^{-0.03}	16.6	4.8	12.2	1.5	0.7

Cylinder
Calculation
SI
SI A.
SIB
SQ
DNT
SC / SU
SCT
SC A.
SL
DN
DSN
DN/DSN A.
MA
MAC
MA/MAC A.
MAL
MALC
MAL/MAC A.
SDA
CQ2
TCQ2
ADN
TADN
PPRM
MHL2
Pneumatic Fingers
MXH/MXQ
CJP
CJ2
CDU
TN
CXs
MGP
MSQ

Cylinder
Calculation
SI
SI A.
SIB
SQ
DNT
SC / SU
SCT
SC A.
SL
DN
DSN
DN/DSN A.
MA
MAC
MA/MAC A.
MAL
MALC
MAL/MAC A.
SDA
CQ2
TCQ2
ADN
TADN
PPRM
MHL2
Pneumatic Fingers
MXH/MXQ
CJP
CJ2
CDU
TN
CXs
MGP
MSQ