

JC Series

Air Filter Combination (3 or 2 Combination)



Feature

- The strength and light valve body is made of quality aluminum alloy.
- The regulator has balanced structure and is featured with good precision and stability.
- The oil cup is more convenient to be oiled.
- The drainage and oil interval is longer depending on the extended type of water cup and oil cup.
- Two combination and three combination share the same bracket and the separated unit including regulator and filter and filter & regulator have their own bracket for easier maintenance.

Ordering Code

J	C	20	02	N
Series	Function Code	Specification	Port Size	Drain
J Series	C: 3 or 2 combination R: Regulator F: Filter L: Lubricator W: Filter-regulator combination	21: 2 Combination	02: G 1/4"	Blank: Manual drain Blank: Standard

Symbol

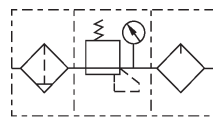

Specification

Model	JC20-02	JC21-02	JW20-02	JR20-02	JF20-02	JL20-02
Rated Flow	500	500	550	550	750	800
Port Size	1/4	1/4	1/4	1/4	1/4	1/4
Filtration	25 μm					
Maximum Working Pressure	1.0 MPa					
Proof Pressure	1.5 MPa					
Operating Temperature Range	5~60 °C					
Adjustable Pressure Range	0.05~0.85 MPa					
Recommended Lubricant	ISO VG 32				ISO VG 32	
Bowl Material	Polycarbonate			Polycarbonate		
Cover	Without					
Drain Function	Manual Drain	Manual Drain	Manual Drain	-	Manual Drain	-
Valve Type	Relieving type					
Components	Filter	Filter & Regulator	-	-	-	-
	Regulator	-	-	-	-	-
	Lubricator	Lubricator	-	-	-	-

JC Series

Air Filter Combination (3 or 2 Combination)

ISO9001:2015 CE

Overall Dimension

JC20-02

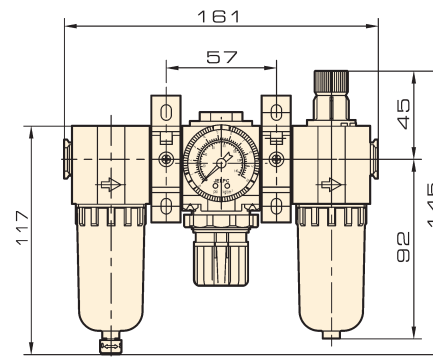

JF20-02

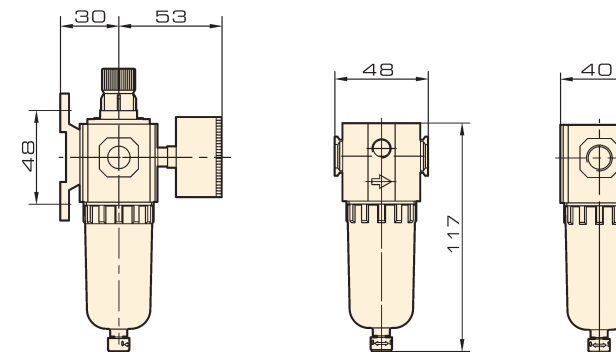

JL20-02

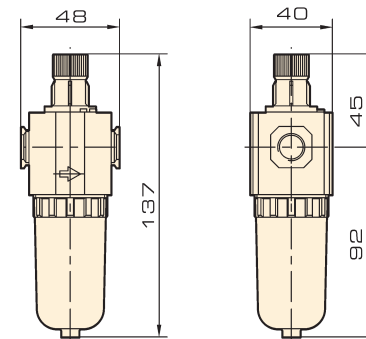

JC21-02

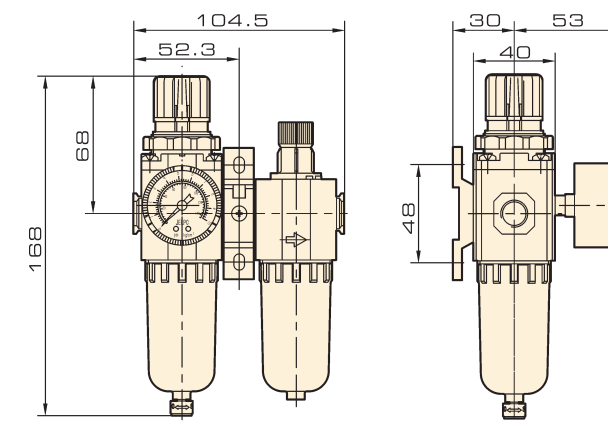

JW20-02

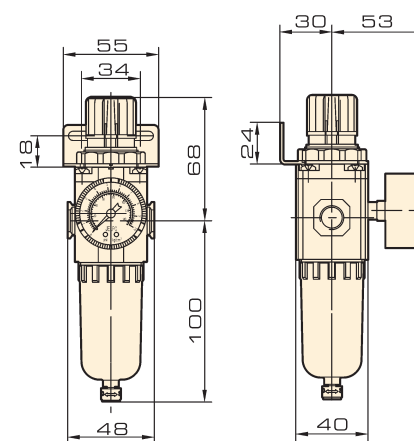

JR20-02

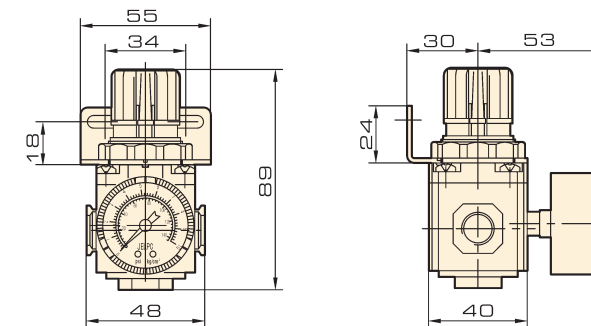

FRL
AC, BC
AFC, BFC
AF, BF
AR, BR
AFR, BFR
AL, BL
JAC
JAF
JAR
JAW
JAL
JC
X-FE
FE
GC
ZYR10
PTH
JAD
DPS

FRL
AC, BC
AFC, BFC
AF, BF
AR, BR
AFR, BFR
AL, BL
JAC
JAF
JAR
JAW
JAL
JC
X-FE
FE
GC
ZYR10
PTH
JAD
DPS