









SL Series Lock Type Cylinder



Cylinder
Calculation
SI
SI A.
SIB
SQ
DNT
SC / SU
SCT
SC A.

SL
DN
DSN
DN/DSN A.
MA
MAC
MA/MAC A.
MAL
MALC
MAL/MAC A.
SDA
CQ2
TCQ2
ADN
TADN
PPRM
MHL2
Pneumatic
Fingers
MXH/MXQ
CJP
CJ2
CDU
TN
CXS
MGP
MSQ

Ordering Code

SL	F	63	x	50	S	LB	MT
Series	Lock Position	Bore		Stroke	Magnet	Mountings	Sensor switch
SL : Lock type cylinder	F : Front cover with Lock  R : Back cover with Lock 	63		50-1000mm	S: With magnet Blank: Without magnet	Blank: Basic mountings LB: Front and back mounting  FA: Front mounting flange FB: Back mounting flange  CA: Back clevis (single earring)  CB: Back hinge (double earring)  TC : Center trunnion TC-M : Trunnion with base mounting 	JEL-21R Type  SC Clamp 

* Standard wire length is 1 meter, please specify for other length

Symbol

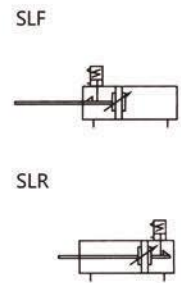

Internal Structure

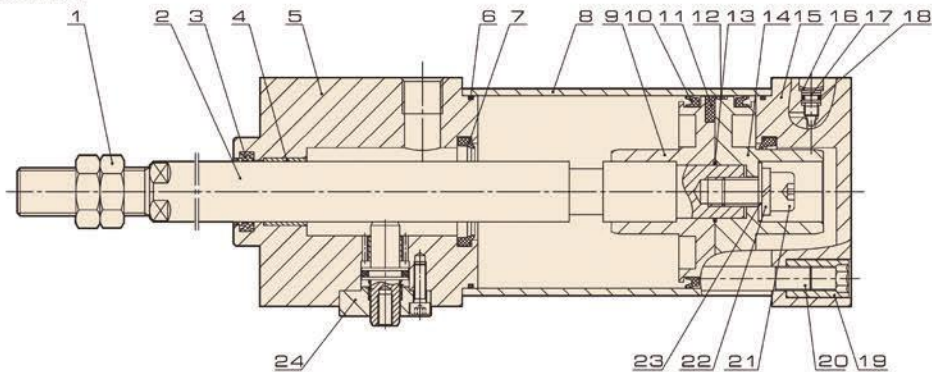

Parts

Item	Name	Item	Name	Item	Name
1	Hexagon thin nut	9	Front piston	17	Regulator pin
2	Piston rod	10	Y ring	18	O ring
3	Anti-dust ring	11	Magnet	19	Tie rod nut
4	DU bearing	12	Lead way bend	20	Tie rod
5	Front cover	13	O ring	21	Inner hexagon pin
6	O ring	14	Back piston	22	Spring washer
7	Cushion ring	15	Backcover	23	Flat washer
8	Barrel	16	Lock slice	24	Lockset