



Features

1. TADN series compact cylinder accord with ISO21287 standard.
2. TADN series cylinder with compact structure, derived lots of variety types, and wide range of applications.
3. Both end use rubber gasket to absorb the remaining energy of the high speed movement and the machine cycle.
4. Every ammsebly way has large number of accessories, so it is very simple.
5. There are two reverse bar positioning on each side to enhance the load capacity for smoother operation.

Ordering Code

TADN	25	x	30	S	MT
Series	Bore	Stroke	Magnet	Sensor	
TADN : Double acting type guide	20 25 32 40 50 63 80 100		Blank: Without magnet S: With magnet	D-Z73 	

* Standard wire length is 1 meter, please specify for other length

Specification

Bore (mm)	20	25	32	40	50	63	80	100
Operation	Double Acting							
Working Medium	Air							
Standard Stroke	5 ~ 100mm							
Operating Pressure Range	0.1 ~ 1.0MPa							
Proof Pressure	1.5MPa							
Operating Temperature Range	-20 ~ 80°C							
Operating Speed Range	30 ~ 500mm/s							
Port Size	G1/8							

- Cylinder
- Calculation
- SI
- SI A.
- SIB
- SQ
- DNT
- SC / SU
- SCT
- SC A.
- SL
- DN
- DSN
- DN/DSN A.
- MA
- MAC
- MA/MAC A.
- MAL
- MALC
- MAL/MALC A.
- SDA
- CQ2
- TCQ2
- ADN
- TADN**
- PPRM
- MHL2
- Pneumatic Fingers
- MXH/MXQ
- CJP
- CJ2
- CDU
- TN
- CXS
- MGP
- MSQ

TADN Series Guide Cylinder



Internal Structure

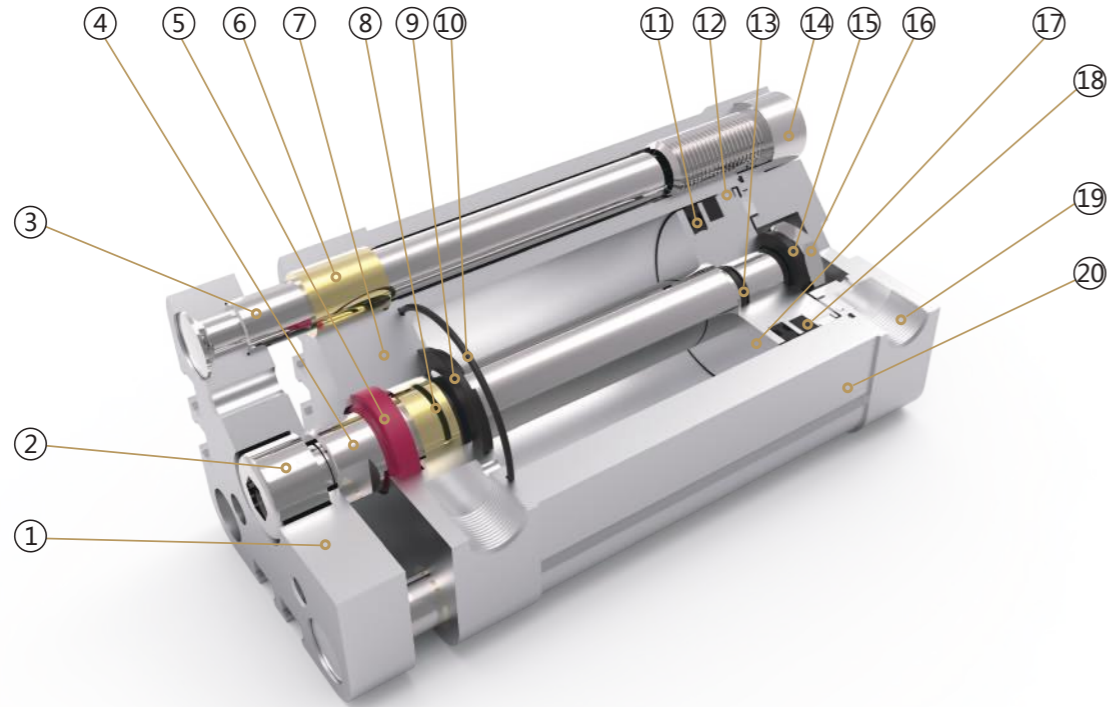

Parts

Number	Name	Number	Name
1	Fixed plate	11	C ring
2	Socket head screw	12	Anti-friction seal
3	Guide rod	13	O ring
4	Piston rod	14	Cover screw
5	Dust ring	15	Small gasket
6	Copper tube	16	Hexagon nut
7	Front cover	17	Piston
8	Bearing	18	Magnet
9	Anti-collision gasket	19	Back cover
10	O ring	20	Barrel

ISO9001:2015 CE

TADN Series Guide Cylinder

Overall Dimension

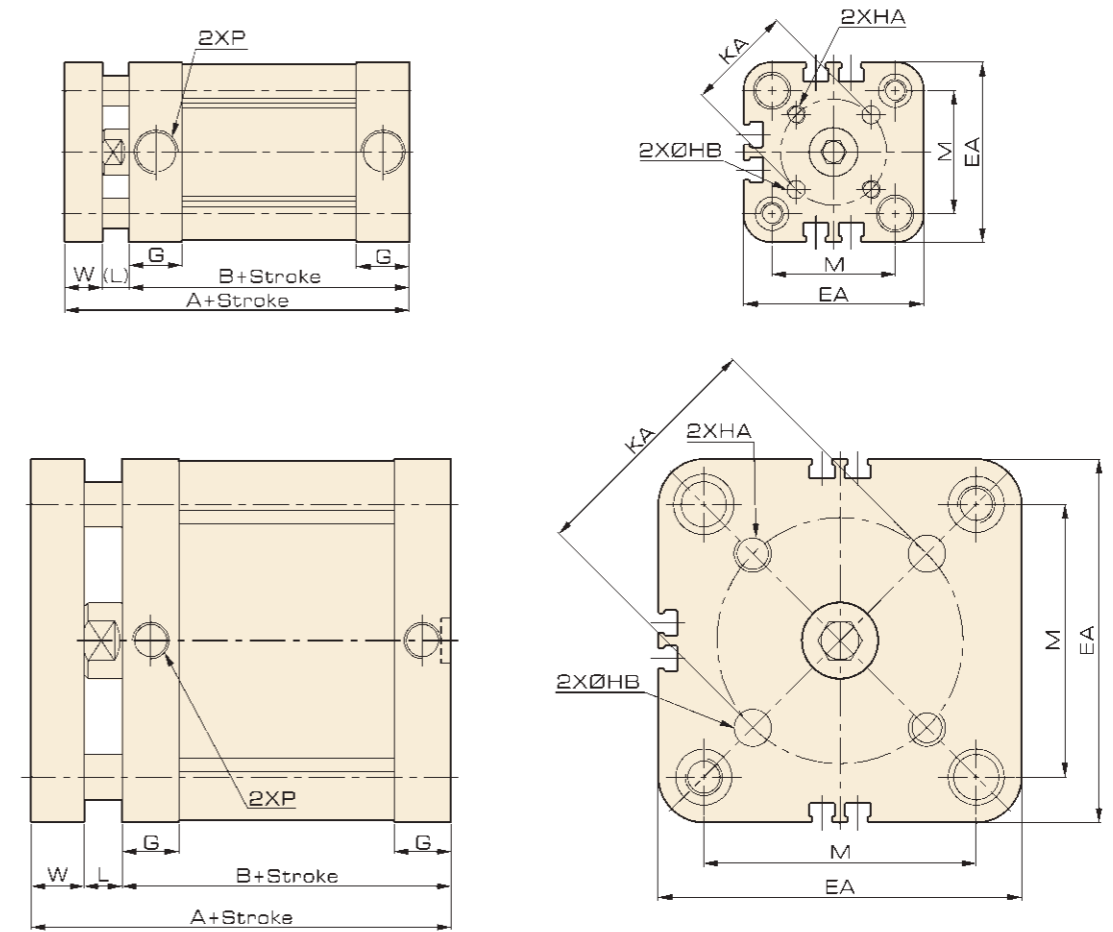

Dimension

Bore Symbol	Stroke Range (mm)	With magnet					EA	M	HA	HB	KA	L	W
		A	B	P									
				-	IN	TF							
20	5-100	51	37	M5X0.8			36	22	M4X0.7	4 ^{+0.2} ₀	17±0.02	6	8
25	5-100	53	39	M5X0.8			40	26	M5X0.8	5 ^{+0.2} ₀	22±0.02	6	8
32	5-100	61	44	G1/8	PT1/8	NPT1/8	47.5	32.5	M5X0.8	5 ^{+0.2} ₀	28±0.02	7	10
40	5-100	62	45	G1/8	PT1/8	NPT1/8	55	38	M5X0.8	5 ^{+0.2} ₀	33±0.02	7	10
50	5-100	65	45	G1/8	PT1/8	NPT1/8	66	46.5	M6X1.0	6 ^{+0.2} ₀	42±0.02	8	12
63	5-100	69	49	G1/8	PT1/8	NPT1/8	78.3	56.5	M6X1.0	6 ^{+0.2} ₀	50±0.02	8	12
80	5-100	78	54	G1/8	PT1/8	NPT1/8	96	72	M8X1.25	8 ^{+0.2} ₀	65±0.02	10	14
100	5-100	91	67	G1/8	PT1/8	NPT1/8	116	89	M10X1.5	10 ^{+0.2} ₀	80±0.02	10	14

Cylinder
Calculation
SI
SI A.
SIB
SQ
DNT
SC / SU
SCT
SC A.
SL
DN
DSN
DN/DSN A.
MA
MAC
MA/MAC A.
MAL
MALC
MAL/MAC A.
SDA
CQ2
TCQ2
ADN
TADN
PPRM
MHL2
Pneumatic Fingers
MXH/MXQ
CJP
CJ2
CDU
TN
CXS
MGP
MSQ

Cylinder
Calculation
SI
SI A.
SIB
SQ
DNT
SC / SU
SCT
SC A.
SL
DN
DSN
DN/DSN A.
MA
MAC
MA/MAC A.
MAL
MALC
MAL/MAC A.
SDA
CQ2
TCQ2
ADN
TADN
PPRM
MHL2
Pneumatic Fingers
MXH/MXQ
CJP
CJ2
CDU
TN
CXS
MGP
MSQ